

3-part design

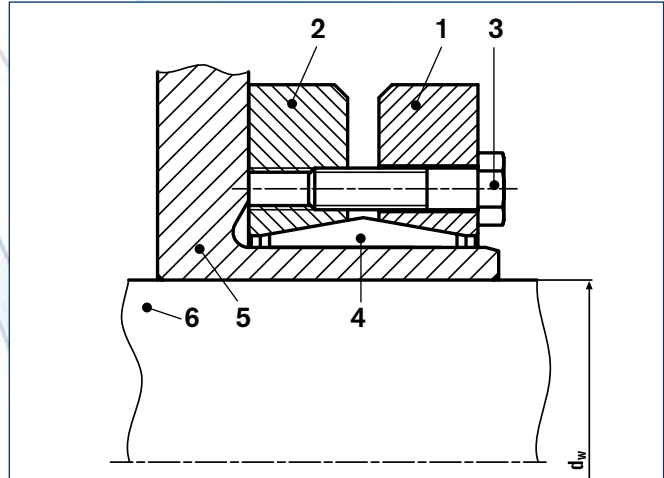

Shrink Discs® RfN 4071: designation of the parts

- 1 front thrust ring
- 2 rear thrust ring
- 3 locking screw
- 4 inner ring
- 5 hub
- 6 shaft

STAINLESS

Installation and removal instructions

Shrink Discs® RfN 4071 Stainless

Installation

1. Clean the area on the shaft where the Shrink Disc® will be seated and oil lightly to ease assembly, if necessary.
Attention: Do not use lubricants containing MOS2.
2. Fasten the attachment part to the Shrink Disc®.
ATTENTION: Tighten the bolts lightly.
3. Slide the Shrink Disc® onto the shaft.
4. Tighten 3 or 4 locking screws that are equally spaced around the diameter to establish a parallel or perpendicular position of Shrink Disc® collar(s) relative to hub web or shaft, respectively. This step properly seats the collar(s) on the taper of the inner ring.
5. Using a torque wrench, tighten all locking screws gradually and in sequence all the way around (not in a diametrically opposite sequence). Several passes may be required until all screws are torqued to the specified tightening torque (T_A).
6. Verify that the screws are completely tight by applying the specified tightening torque (T_A). The gap between the Shrink Disc® collars or between the Shrink Disc® collar and the hub should be even all the way around.

Removal

1. Loosen the bolts evenly and in sequence, again in several circular sequences, to avoid jamming of the discs on the inner ring. Never completely remove the bolts from their threaded holes, this creates a risk of accidents.
2. Slide the Shrink Disc® and its attachment part from the shaft. First remove possible traces of rust from the shaft.
3. Release the attachment part from the Shrink Disc®.

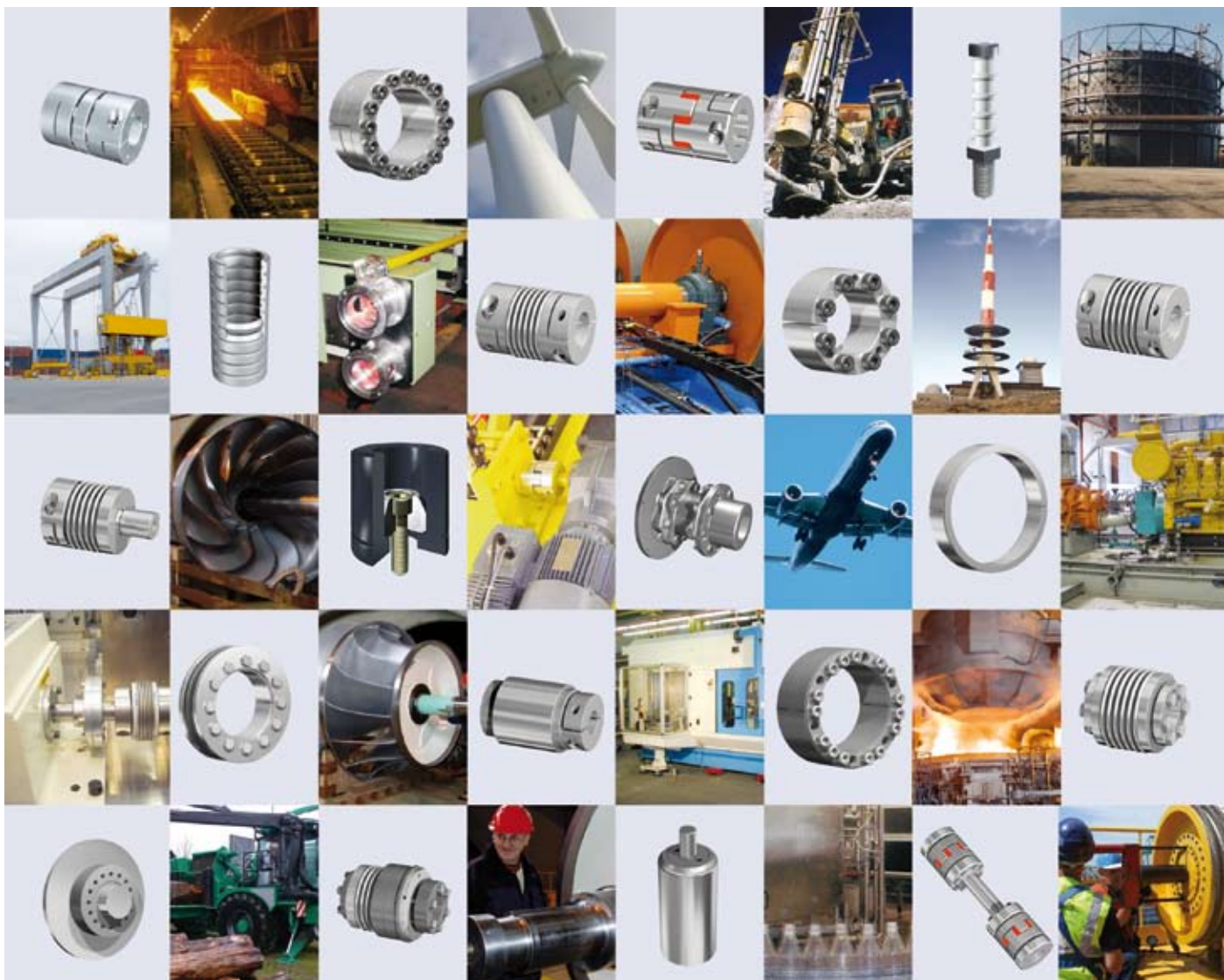

Weitere technische Hinweise befinden sich im jeweiligen Katalog.

Alle technischen Daten und Hinweise sind unverbindlich. Rechtsansprüche können daraus nicht abgeleitet werden. Der Anwender ist grundsätzlich verpflichtet zu prüfen, ob die dargestellten Produkte seinen Anforderungen genügen. Änderungen, die dem technischen Fortschritt dienen, behalten wir uns jederzeit vor. Mit Erscheinen dieses Kataloges werden alle älteren Prospekte und Fragebögen zu den gezeigten Produkten ungültig.

Check out the respective catalogue for further technical details

All technical details and information is non-binding and cannot be used as a basis for legal claims. The user is obligated to determine whether the represented products meet his requirements. We reserve the right at all times to carry out modifications in the interests of technical progress. Upon the issue of this catalogue all previous brochures and questionnaires on the products displayed are no longer valid.

RINGFEDER POWER TRANSMISSION GMBH

- Oberschlesienstr. 15, D-47807 Krefeld, Germany · Phone: +49 (0) 2151 835-232 · Fax: +49 (0) 2151 835-19232 · E-mail: sales.international@ringfeder.com
- Lützelalter Str. 5a, D-63868 Großwallstadt, Germany · Phone: +49 (0) 6022 2204-0 · Fax: +49 (0) 6022 2204-11 · E-mail: sales.international@gerwah.com

RINGFEDER POWER TRANSMISSION INDIA PRIVATE LIMITED

- Plot No. 4, Door No. 220, Mount Poonamallee High Road, Kattupakkam, Chennai – 600 056, India · Phone: +91 44 26496-411 · Fax: +91 44 26496-422
- E-mail: sales.india@ringfeder.com · E-mail: sales.india@gerwah.com

RINGFEDER POWER TRANSMISSION CORPORATION

- 165 Carver Avenue, P.O. Box 691 Westwood, NJ 07675, USA · Toll Free: +1 888 746-4333 · Phone: +1 201 666 3320 · Fax: +1 201 664 6053
- E-mail: sales.usa@ringfeder.com · E-mail: sales.usa@gerwah.com