

Shrink Disc® RINGFEDER® RfN 4071 split · Location

Split Shrink Discs®

In the application shown above special screws according to the dimension X are required, which have to be ordered accordingly. If the dimension X is above $2 \times L$ (L taken from the Standard and the Light Duty Series) or above $1 \times L$ (taken from the Heavy Duty Series) the transmissible torque may be reduced by up to 50%.

Half Shrink Discs®

With half shrink discs® HC/HT only 50% of stated T is transmitted.

type HT (Threaded holes in thrust ring)

type HC (Clearance holes in thrust ring)

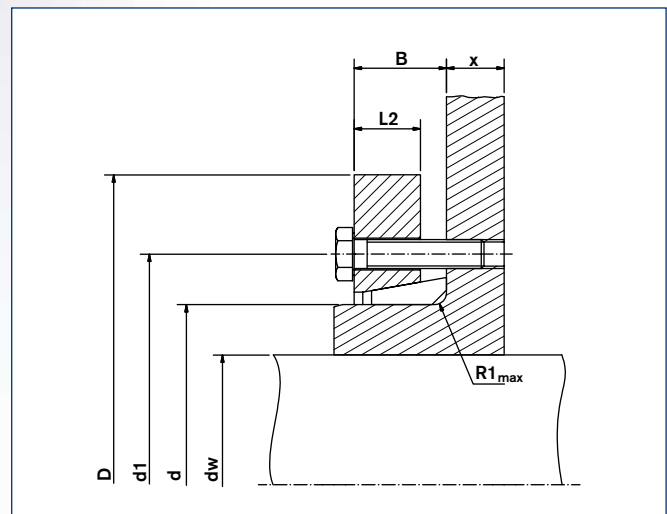

Shrink Disc® RINGFEDER® RfN 4071 HC · Dimensions

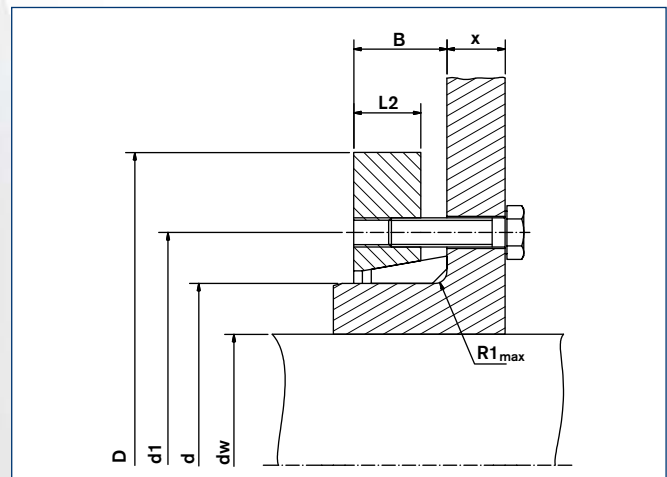

Shrink Disc® RINGFEDER® RfN 4071 HT version

| Size | Shrink Disc® dimensions | | | | | | | | | T _A | Transmissible torques or axial forces | | Locking screws DIN EN ISO 4014-10.9 | | Weight | |
|------|-------------------------|----------------|--------|---------------|--------|----------------|----------------|---------|---------|----------------|---------------------------------------|-----------------|--|---------|--------|------------------|
| | d _w | C _w | d | Ch | D | L ₂ | d ₁ | B±0.039 | R1 max | | T | F _{ax} | Quantity | Thread | WT | T _{max} |
| | Inch | Inch | Inch | Inch | Inch | Inch | Inch | Inch | Inch | lb-ft | lb-ft | lbs | n | | lbs | lb-ft |
| 220 | 6.299 | 0.0031 | 8.661 | +0 -0.0028 | 14.567 | 1.850 | 10.630 | 2.343 | 0.291 | 184 | 70068 | 267512 | 15 | M16 | 119 | 77075 |
| | 81132 | | | | | | | | | | 289992 | 89245 | | | | |
| 240 | 6.693 | | 8.661 | | 14.567 | 1.850 | 10.630 | 2.343 | 0.291 | 184 | 70068 | 267512 | 15 | M16 | 119 | 77075 |
| | 6.693 | 9.449 | 15.945 | 1.929 | 11.614 | 2.441 | 0.291 | 361 | 81132 | 289992 | 12 | M20 | 148 | 97358 | | |
| 260 | 7.480 | 0.0035 | 10.236 | +0 -0.0032 | 16.929 | 2.126 | 12.638 | 2.657 | 0.291 | 361 | 115059 | 376540 | 14 | M20 | 181 | 126565 |
| | 120960 | | | | | | | | | | 395648 | 133056 | | | | |
| 280 | 7.480 | | 10.236 | | 16.929 | 2.126 | 12.638 | 2.657 | 0.291 | 361 | 115059 | 376540 | 14 | M20 | 181 | 126565 |
| | 8.268 | 11.024 | 18.110 | 2.362 | 13.622 | 3.012 | 0.331 | 361 | 151200 | 451848 | 16 | M20 | 225 | 176056 | | |
| 300 | 8.268 | 0.0040 | 11.024 | +0 -0.0035 | 18.110 | 2.362 | 13.622 | 3.012 | 0.331 | 361 | 179965 | 499056 | 18 | M20 | 260 | 219055 |
| | 199141 | | | | | | | | | | 528280 | 223112 | | | | |
| 320 | 9.055 | | 11.024 | | 19.094 | 2.520 | 14.331 | 3.130 | 0.331 | 361 | 202829 | 546489 | 18 | M20 | 260 | 219055 |
| | 9.055 | 11.811 | 19.094 | 2.520 | 14.331 | 3.130 | 0.331 | 361 | 232331 | 592573 | 20 | M20 | 289 | 255565 | | |
| 340 | 9.646 | 0.0044 | 12.598 | +0 -0.0035 | 20.472 | 2.520 | 15.197 | 3.130 | 0.331 | 361 | 230119 | 595046 | 24 | M20 | 410 | 253131 |
| | 275847 | | | | | | | | | | 651920 | 303432 | | | | |
| 360 | 9.449 | | 12.598 | | 20.472 | 2.520 | 15.197 | 3.130 | 0.331 | 361 | 275847 | 651920 | 20 | M20 | 289 | 255565 |
| | 10.236 | 13.386 | 22.441 | 2.795 | 16.063 | 3.406 | 0.331 | 361 | 287648 | 701151 | 24 | M20 | 410 | 316413 | | |
| 380 | 9.843 | 0.0040 | 13.386 | +0 -0.0035 | 22.441 | 2.795 | 16.063 | 3.406 | 0.331 | 361 | 339278 | 764320 | 24 | M20 | 430 | 373205 |
| | 326002 | | | | | | | | | | 736445 | 358602 | | | | |
| 390 | 10.630 | | 13.386 | | 22.441 | 2.795 | 16.063 | 3.406 | 0.331 | 361 | 339278 | 764320 | 24 | M20 | 430 | 373205 |
| | 10.630 | 13.780 | 22.835 | 2.874 | 17.008 | 3.524 | 0.331 | 361 | 368780 | 786800 | 24 | M20 | 430 | 405658 | | |
| 400 | 11.220 | 0.0044 | 13.780 | +0 -0.0035 | 22.835 | 2.874 | 17.008 | 3.524 | 0.331 | 361 | 341490 | 744088 | 24 | M20 | 450 | 375639 |
| | 385006 | | | | | | | | | | 794893 | 423507 | | | | |
| 420 | 11.024 | | 13.780 | | 22.835 | 2.874 | 17.008 | 3.524 | 0.331 | 361 | 341490 | 744088 | 24 | M20 | 450 | 375639 |
| | 11.614 | 14.173 | 23.228 | 2.874 | 17.008 | 3.524 | 0.331 | 361 | 418197 | 878968 | 20 | M24 | 527 | 460016 | | |
| 440 | 11.417 | 0.0044 | 14.173 | +0 -0.0038 | 23.228 | 2.874 | 17.008 | 3.524 | 0.331 | 620 | 485314 | 954950 | 21 | M24 | 573 | 533846 |
| | 460237 | | | | | | | | | | 935168 | 506261 | | | | |
| 460 | 12.205 | | 14.173 | | 23.228 | 2.874 | 17.008 | 3.524 | 0.331 | 361 | 460237 | 935168 | 21 | M24 | 573 | 506261 |
| | 11.811 | 15.354 | 25.984 | 2.992 | 18.425 | 3.642 | 0.331 | 620 | 529568 | 1008003 | 21 | M24 | 617 | 582525 | | |
| 480 | 12.598 | 0.0048 | 15.354 | +0 -0.0038 | 25.984 | 2.992 | 18.425 | 3.642 | 0.331 | 620 | 494165 | 957648 | 21 | M24 | 617 | 543582 |
| | 548745 | | | | | | | | | | 1011600 | 603619 | | | | |
| 500 | 12.402 | | 15.354 | | 25.984 | 2.992 | 18.425 | 3.642 | 0.331 | 620 | 494165 | 957648 | 21 | M24 | 617 | 543582 |
| | 12.992 | 16.535 | 27.165 | 3.386 | 19.843 | 4.193 | 0.390 | 620 | 575297 | 1090280 | 24 | M24 | 697 | 632826 | | |
| 420 | 12.992 | 0.0044 | 16.535 | +0 -0.0038 | 27.165 | 3.386 | 19.843 | 4.193 | 0.390 | 620 | 663804 | 1173456 | 24 | M24 | 900 | 730184 |
| | 594473 | | | | | | | | | | 1065552 | 653921 | | | | |
| 440 | 13.780 | | 16.535 | | 27.165 | 3.386 | 19.843 | 4.193 | 0.390 | 620 | 663804 | 1173456 | 24 | M24 | 900 | 730184 |
| | 13.386 | 17.323 | 29.528 | 3.583 | 20.748 | 4.469 | 0.390 | 620 | 676343 | 1144232 | 24 | M24 | 900 | 743977 | | |
| 460 | 14.173 | 0.0048 | 17.323 | +0 -0.0038 | 29.528 | 3.583 | 20.748 | 4.469 | 0.390 | 620 | 737560 | 1274616 | 28 | M24 | 926 | 811316 |
| | 1032584 | | | | | | | | | | 1360040 | 1135842 | | | | |
| 480 | 14.173 | | 17.323 | | 29.528 | 3.583 | 20.748 | 4.469 | 0.390 | 620 | 737560 | 1274616 | 28 | M24 | 926 | 811316 |
| | 14.961 | 18.110 | 30.315 | 3.583 | 21.535 | 4.469 | 0.390 | 620 | 862945 | 1382520 | 30 | M24 | 1114 | 949240 | | |
| 500 | 14.961 | 0.0048 | 18.110 | +0 -0.0038 | 30.315 | 3.583 | 21.535 | 4.469 | 0.390 | 620 | 966204 | 1472440 | 24 | M27 | 1268 | 1062824 |
| | 967679 | | | | | | | | | | 1474688 | 1064447 | | | | |
| 500 | 15.748 | | 18.110 | | 30.315 | 3.583 | 21.535 | 4.469 | 0.390 | 620 | 966204 | 1472440 | 24 | M27 | 1268 | 1062824 |
| | 15.748 | 19.685 | 33.465 | 3.780 | 23.228 | 4.685 | 0.390 | 922 | 967679 | 1474688 | 24 | M27 | 1268 | 1064447 | | |
| | 16.535 | 19.685 | 33.465 | 3.780 | 23.228 | 4.685 | 0.390 | 922 | 1073150 | 1557864 | 24 | M27 | 1268 | 1180465 | | |

Explanations to tables

d, D, L, l, L₁, L₂, d₁ = Basic dimensions

d_w = solid shaft diameter (provided by the customer)

T = transmissible torque

F_{ax} = transmissible axial force

p = approx. surface pressure on the hub extension (diameter d)

T_A = required tightening torque per screw (Screws greased with molykote or equivalent!)

n = quantity of screws

T_{max} = maximum theoretical transmissible torque

C_w = shaft clearances

C_n = hub tolerances

C_d = shaft tolerances

|l₁ = Inner ring centering shoulder length

d₂ = clamped component bore

x = clamped component thickness

B = width dimension, relaxed condition

R₁ = hub max. radius (split Shrink Disc®)

s_v = calculated combined stress in the hub extension (d/dw) under consideration of the tangential, radial and torsional stresses following the equation:

$$\sigma_v = \sqrt{1/2 [(\sigma_x - \sigma_y)^2 + (\sigma_y - \sigma_z)^2 + (\sigma_z - \sigma_x)^2] + 3\tau^2}$$

Additional loads, e.g. tension, thrust or bending have to be taken into consideration accordingly.

Function values

The functional characteristics are valid with the screw tightening torque listed in the tables and the following assumed conditions:

The locking screws are lubricated using MoS₂ (μ_{tot} = 0.1).

The tapered cones are lubricated using MoS₂ (μ = 0.05).

The contact surfaces (d_w) are in lightly oiled condition with coefficient of friction μ = 0.12.

The hub and shaft materials have a modulus of elasticity of 30 x 10⁶ PSI. (Lower values result in increased values for T and Fax with reduced tangential stress.)

The maximum clearance is being fully utilized.

The shaft being used is solid, for hollow shaft applications the functional values will change.

In cases where the assumed conditions do not apply then contact our Technical Department where we will be happy to assist you with your application.



Weitere technische Hinweise befinden sich im jeweiligen Katalog.

Alle technischen Daten und Hinweise sind unverbindlich. Rechtsansprüche können daraus nicht abgeleitet werden. Der Anwender ist grundsätzlich verpflichtet zu prüfen, ob die dargestellten Produkte seinen Anforderungen genügen. Änderungen, die dem technischen Fortschritt dienen, behalten wir uns jederzeit vor. Mit Erscheinen dieses Kataloges werden alle älteren Prospekte und Fragebögen zu den gezeigten Produkten ungültig.

Check out the respective catalogue for further technical details

All technical details and information is non-binding and cannot be used as a basis for legal claims. The user is obligated to determine whether the represented products meet his requirements. We reserve the right at all times to carry out modifications in the interests of technical progress. Upon the issue of this catalogue all previous brochures and questionnaires on the products displayed are no longer valid.

RINGFEDER POWER TRANSMISSION GMBH

Werner-Heisenberg-Straße 18, D-64823 Groß-Umstadt, Germany · Phone: +49 (0) 6078 9385-0 · Fax: +49 (0) 6078 9385-100
E-mail: sales.international@ringfeder.com · E-mail: sales.international@gerwah.com

RINGFEDER POWER TRANSMISSION USA CORPORATION

165 Carver Avenue, P.O. Box 691 Westwood, NJ 07675, USA · Toll Free: +1 888 746-4333 · Phone: +1 201 666 3320
Fax: +1 201 664 6053 · E-mail: sales.usa@ringfeder.com · E-mail: sales.usa@gerwah.com

RINGFEDER POWER TRANSMISSION INDIA PRIVATE LIMITED

Plot No. 4, Door No. 220, Mount - Poonamallee Road, Kattupakkam, Chennai – 600 056, India
Phone: +91 (0) 44-2679-1411 · Fax: +91 (0) 44-2679-1422 · E-mail: sales.india@ringfeder.com · E-mail: sales.india@gerwah.com

KUNSHAN RINGFEDER POWER TRANSMISSION COMPANY LIMITED

German Industry Park, No. 508 Hengguanjiang Road, Zhangpu Town 215321, Kunshan City, P.R. China
Phone: +86 (0) 512-5745-3960 · Fax: +86 (0) 512-5745-3961 · E-mail sales.china@ringfeder.com